

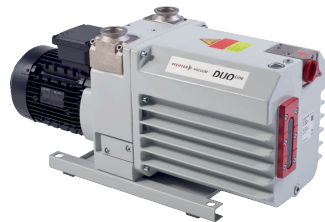

**Duo 35, 220/380 V, 60 Hz,
3TF**



Duo 35



Duo 35, 220/380 V, 60 Hz, 3TF

- Dual-stage, high-performance rotary vane pump with a pumping speed up to 36 m³/h
- With 3-phase motor
- With temperature sensor (3TF) for optimum motor protection
- Integrated gas ballast and HV safety valve
- For all low and medium vacuum applications
- Special feature: Various motor voltages for worldwide employment
- Other motor voltages available on request

Characteristics

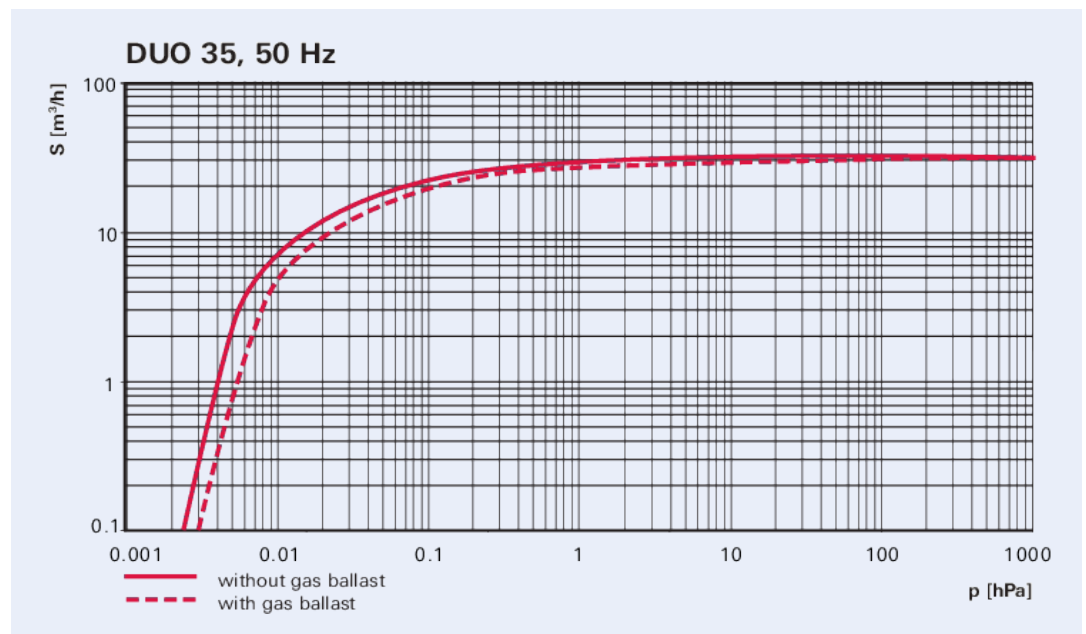

Dimensions

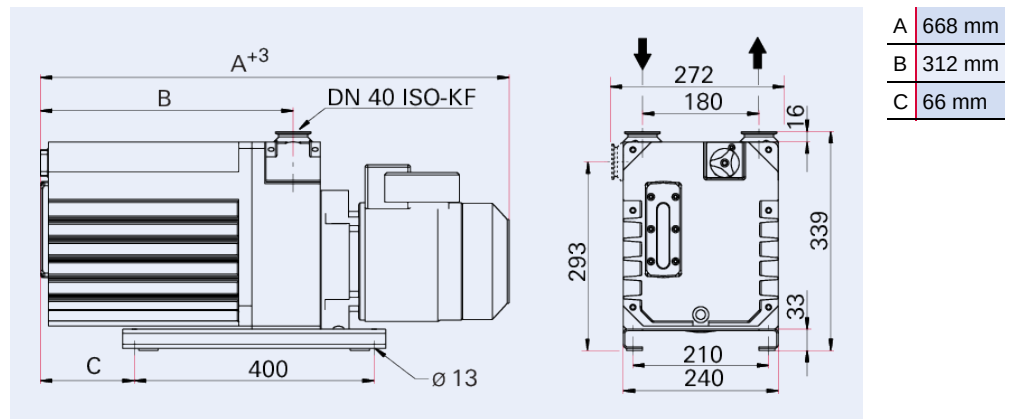

Technical Data

Duo 35, 220/380 V, 60 Hz, 3TF

Connection flange (in)	DN 40 ISO-KF
Connection flange (out)	DN 40 ISO-KF
Pumping speed at 60 Hz	36 m ³ /h 21.1896 cfm 600.012 l/min
Ultimate pressure	2 · 10 ⁻³ hPa 1.5 · 10 ⁻³ Torr 2 · 10 ⁻³ mbar
Ultimate pressure with gas ballast	3 · 10 ⁻³ hPa 2.25 · 10 ⁻³ Torr 3 · 10 ⁻³ mbar
Exhaust pressure, min.	Atmospheric pressure
Exhaust pressure, max.	1,500 hPa 1,125 Torr 1,500 mbar
Water vapor capacity 60 Hz	510 g/h
Water vapor tolerance at 60 Hz	20 hPa 15 Torr 20 mbar
Rotation speed at 60 Hz	1,800 rpm 1,800 min ⁻¹
Cooling method	Air (Forced convection)
Motor protection	3TF
Motor type	3-phase motor
Ambient temperature	12 – 40 °C
Emission sound pressure level without gas ballast at 60 Hz	≤64 dB(A)
Switch	No
Switch included	No
Input voltage 60 Hz	220 / 380 V
Input voltage(s)	220 / 380 V AC (±5 %), 60 Hz
Mains cable included	No
Mains cable	No
Gas ballast	Yes
Operating fluid	P3
Operating fluid amount	3.2 l
Leakage rate safety valve	≤1 · 10 ⁻⁵ Pa m ³ /s ≤7.5 · 10 ⁻⁵ Torr l/s ≤1 · 10 ⁻⁴ mbar l/s
Dimensions (L x W x H)	661 x 240 x 340 mm
Input voltage: tolerance	±5 %
Rated power 60 Hz	1.3 kW
Protection degree	IP55
Weight	68 kg 149.91 lb

Order number	Duo 35, 220/380 V, 60 Hz, 3TF
Duo 35, 220/380 V, 60 Hz, 3TF	PK D45 642

Accessories	Duo 35, 220/380 V, 60 Hz, 3TF
Set of seals for UNO/DUO 35/65 Standard, M, MC	PK E20 001 -T
Maintenance kit for UNO / DUO 35/65	PK E21 001 -T
Maintenance kit, level 1 for Uno/Duo 35/65 RWDR / M / C / MC	PK E21 005 -T
Overhaul kit for DUO 35	PK E22 005 -T
Pumping system for DUO 35 tested with operating fluid P3	PK E23 003 -T
HV valve kit for UNO/DUO 35/65	PK E24 001 -T
Pressure valve kit for UNO 35, DUO 35 / 35M	PK E25 001 -T
Coupling kit for UNO/DUO 35/35C/65/C	PK E26 001 -T
Set of vanes for DUO 35 / 35 M	PK E28 003 -T

Your Success. Our Passion.

We give our best for you every day –
worldwide!

Are you looking for an optimum vacuum solution?

Talk to us:
Pfeiffer Vacuum GmbH
Germany
T +49 6441 802-0

Or scan the barcode, to visit our web page:



<https://webportal.pfeiffer-vacuum.com/global/en/contact>



Errors and/or changes excepted. - 11/1/2024

Follow Us On Social Media
#pfeiffervacuum



www.pfeiffer-vacuum.com

PFEIFFER  **VACUUM**