

OPERATING INSTRUCTIONS

EN

Translation of the Original

PLUG-IN BOARDS

for total pressure measuring and control units TPG 300/TPG 500

Dear Customer,

Thank you for choosing a Pfeiffer Vacuum product. Your new total pressure measuring and control unit should support you in your individual application with full performance and without malfunctions. The name Pfeiffer Vacuum stands for high-quality vacuum technology, a comprehensive and complete range of top-quality products and first-class service. From this extensive, practical experience we have gained a large volume of information that can contribute to efficient deployment and to your personal safety.

In the knowledge that our product must avoid consuming work output, we trust that our product can offer you a solution that supports you in the effective and trouble-free implementation of your individual application.

Please read these operating instructions before putting your product into operation for the first time. If you have any questions or suggestions, please feel free to contact info@pfeiffer-vacuum.de.

Further operating instructions from Pfeiffer Vacuum can be found in the [Download Center](#) on our website.

Disclaimer of liability

These operating instructions describe all models and variants of your product. Note that your product may not be equipped with all features described in this document. Pfeiffer Vacuum constantly adapts its products to the latest state of the art without prior notice. Please take into account that online operating instructions can deviate from the printed operating instructions supplied with your product.

Furthermore, Pfeiffer Vacuum assumes no responsibility or liability for damage resulting from the use of the product that contradicts its proper use or is explicitly defined as foreseeable misuse.

Copyright

This document is the intellectual property of Pfeiffer Vacuum and all contents of this document are protected by copyright. They may not be copied, altered, reproduced or published without the prior written permission of Pfeiffer Vacuum.

We reserve the right to make changes to the technical data and information in this document.

Table of contents

1	About this manual	7
1.1	Validity	7
	1.1.1 Applicable documents	7
	1.1.2 Variants	7
1.2	Target group	8
1.3	Conventions	8
	1.3.1 Instructions in the text	8
	1.3.2 Pictographs	8
	1.3.3 Abbreviations	8
1.4	Trademark proof	9
2	Safety	10
2.1	General safety information	10
2.2	Safety instructions	10
2.3	Safety precautions	11
2.4	Proper use	11
2.5	Foreseeable improper use	12
3	Product description	13
3.1	Function	13
	3.1.1 Pirani measurement system	13
	3.1.2 Cold cathode measuring system	13
3.2	Identifying the product	13
3.3	Structure of plug-in boards	13
	3.3.1 Pirani measurement boards	13
	3.3.2 Cold cathode measurement boards	13
	3.3.3 Pirani/cold cathode measurement boards	13
	3.3.4 Interface and relay boards	14
3.4	Interfaces	14
	3.4.1 "OUTPUT" connection on PI 300 and CP 300	14
	3.4.2 "CONTROL" connection on PE 300 DC9	14
	3.4.3 "RELAY" connection on IF 300A/C/P	15
	3.4.4 "RELAY" connection on IF 300B	15
	3.4.5 "RS-232" connection on IF 300A	16
	3.4.6 "RS-232" connection on IF 300B	16
	3.4.7 "RS-422" connection on IF 300C	17
	3.4.8 "Profibus" connection on IF 300P	17
	3.4.9 "Profinet" connection on IF 500 PN	18
3.5	Scope of delivery	19
4	Transport and storage	20
4.1	Transporting product	20
4.2	Storing product	20
5	Installation	22
5.1	Installing/removing plug-in boards	22
5.2	Connecting gauges	22
	5.2.1 Connecting Pirani gauges	22
	5.2.2 Connecting the cold cathode gauge	23
5.3	Connecting interfaces and connections	24
	5.3.1 Connecting the analog signal to the measurement boards	24
	5.3.2 Connecting relays to the interface boards	24
	5.3.3 Connecting "RS-232-C" interface of IF 300A	25
	5.3.4 Connecting "RS-232-C" interface of IF 300B	25
	5.3.5 Connecting "RS-422" interface of IF 300 C	25
	5.3.6 Connecting "Profibus-DP" interface of IF 300 P	26

	5.3.7 Connecting "Profinet" interface of IF 500 PN	26
6	Operation	27
7	Calibrating Pirani measuring circuit	28
8	Malfunctions	29
9	Shipping	31
10	Recycling and disposal	32
	10.1 General disposal information	32
	10.2 Disposing of plug-in boards	32
11	Service solutions by Pfeiffer Vacuum	33
12	Accessories	35
	12.1 Accessory information	35
	12.2 Ordering accessories	35
13	Technical data and dimensions	39
	13.1 Technical data	39
	13.2 Dimensions	43
14	Appendix	45
	14.1 Units of pressure	45
	14.2 Gas throughputs	45
	14.3 Converting measuring signal and pressure	46
	14.4 Gas type dependence	47

List of tables

Tbl. 1:	Applicable documents	7
Tbl. 2:	Variants	7
Tbl. 3:	Abbreviations used	9
Tbl. 4:	Switch functions on IF 300A/C/P	15
Tbl. 5:	Switching functions on IF 300B	16
Tbl. 6:	Disturbances during installation	29
Tbl. 7:	Interference during operation and calibration	29
Tbl. 8:	Disturbances as a result of defects	29
Tbl. 9:	Disturbances with the RS-232-C interface	30
Tbl. 10:	Disturbances with the RS-422 interface	30
Tbl. 11:	Disturbances with the Profibus-DP interface	30
Tbl. 12:	Disturbances with the Profinet interface	30
Tbl. 13:	Pirani gauges	35
Tbl. 14:	Cold cathode gauges	35
Tbl. 15:	Measuring cable for TPR 010	36
Tbl. 16:	Measuring cable for TPR 017 and TPR 018	36
Tbl. 17:	Extension cable for TPR 010, TPR 017 and TPR 018	37
Tbl. 18:	Measuring cable for IKR 050 and IKR 060	37
Tbl. 19:	Measuring cable for IKR 070	37
Tbl. 20:	Plugs and interface cable	37
Tbl. 21:	Dummy plates	38
Tbl. 22:	Technical data, PI 300 D / PI 300 DN	39
Tbl. 23:	Technical data, PE 300 DC9	39
Tbl. 24:	Technical data, CP 300 C9/C10/T11/T11L	41
Tbl. 25:	Technical data IF 300A	41
Tbl. 26:	Technical data IF 300B	42
Tbl. 27:	Technical data, IF 300 C	42
Tbl. 28:	Technical data, IF 300 P	43
Tbl. 29:	Technical data, IF 500 PN	43
Tbl. 30:	Units of pressure and their conversion	45
Tbl. 31:	Gas throughputs and their conversion	45

List of figures

Fig. 1:	"OUTPUT" connection with 2 sockets	14
Fig. 2:	"CONTROL" connection on PE 300 DC9	14
Fig. 3:	Switch and logic on the "CONTROL" connection	15
Fig. 4:	"RELAY" connection on IF 300A/C/P	15
Fig. 5:	"RELAY" connection on IF 300B	15
Fig. 6:	"RS-232" connection on IF 300A	16
Fig. 7:	"RS-232" connection on IF 300B	16
Fig. 8:	"RS-422" connection on IF 300C	17
Fig. 9:	"Profibus" connection on IF 300P	18
Fig. 10:	"Profinet" connection on IF 500 PN	18
Fig. 11:	"RJ-45" connection on IF 500 PN	18
Fig. 12:	Coax cable and triax cable	23
Fig. 13:	Locking the triax plug	24
Fig. 14:	Folding ferrite for IF 300B	24
Fig. 15:	Connecting interface cable to IF 300B	25
Fig. 16:	ATM and HIGH VAC trimming potentiometers	28
Fig. 17:	Pirani measuring cable connection diagram	36
Fig. 18:	Pirani extension cable connection diagram	36
Fig. 19:	Dimensions of measurement boards	43
Fig. 20:	Dimensions of interface and relay boards	44
Fig. 21:	Relationship between measuring signal and pressure for TPR gauges	46
Fig. 22:	Relationship between measuring signal and pressure for IKR gauges	47
Fig. 23:	Displayed pressure for TPR gauges	48
Fig. 24:	Displayed pressure for IKR gauges	48

1 About this manual



IMPORTANT

Read carefully before use.
Keep the manual for future consultation.

1.1 Validity

This document describes the function of the products listed in the following and provides the most important information for safe use. The description is written in accordance with the valid directives. The information in this document refers to the current development status of the products. The document retains its validity assuming that the customer does not make any changes to the product.

1.1.1 Applicable documents

Designation	Document
"Total Pressure Measuring and Control Unit" operating instructions TPG 300	BG 5970
"Profibus" communication instructions TPG 300 / TPG 500	BG 5973
"Total Pressure Measuring and Control Unit" operating instructions TPG 500	BG 6008
"Serial interface" communication instructions TPG 500	BG 6009
"Profinet" communication instructions TPG 500	BG 6014
"Gauges" operating instructions ModulLine gauges	(depending on the gauge used)

Tbl. 1: Applicable documents

You can find these documents in the [Pfeiffer Vacuum Download Center](#).

1.1.2 Variants

This document applies to the products with the following part numbers:

Article number	Type	Designation
PT 546 920-T	Measurement board (Pirani)	PI 300 D
PT 549 214-T		PI 300 DN
PT 441 375-T	Measurement board (cold cathode)	PE 300 DC9
PT 441 000-T	Measurement board (Pirani/cold cathode)	CP 300 C9
PT 441 114-T		CP 300 C10
PT 441 080-T		CP 300 T11
PT 441 120-T		CP 300 T11L
PT 441 130-T		Interface and relay board (RS-232-C)
PT 441 250-T	IF 300B	
PT 441 390-T	Interface and relay board (RS-422)	IF 300 C
PT 441 395-T	Interface and relay board (Profibus)	IF 300 P
PT 441 595-T	Interface board (Profinet)	IF 500 PN

Tbl. 2: Variants

You can find the part number on the rating plate of the product.

Pfeiffer Vacuum reserves the right to make technical changes without prior notification.

The figures in this document are not to scale.
Dimensions are in mm unless stated otherwise.

1.2 Target group

These operating instructions are aimed at all persons performing the following activities on the product:

- Transportation
- Setup (Installation)
- Usage and operation
- Decommissioning
- Maintenance and cleaning
- Storage or disposal

The work described in this document is only permitted to be performed by persons with the appropriate technical qualifications (expert personnel) or who have received the relevant training from Pfeiffer Vacuum.

1.3 Conventions

1.3.1 Instructions in the text

Usage instructions in the document follow a general structure that is complete in itself. The required action is indicated by an individual step or multi-part action steps.

Individual action step

A horizontal, solid triangle indicates the only step in an action.

- ▶ This is an individual action step.

Sequence of multi-part action steps

The numerical list indicates an action with multiple necessary steps.

1. Step 1
2. Step 2
3. ...

1.3.2 Pictographs

Pictographs used in the document indicate useful information.



Note



Tip

1.3.3 Abbreviations

Abbreviation	Explanation
ASCII	American Standard Code for Information Interchange
ATM	Atmosphere
C	Calibration factor for calculating pressure for gases other than air
CNTR-P	Repeater direction control signal (Profibus)
ESD	Electrostatic discharge
IF	Interface
GND	Ground
HV	High vacuum
MHV	Coax high voltage connector in miniature design (miniature high voltage)
MSL	Mean sea level
PE	Penning

Abbreviation	Explanation
P GND	Protective ground
Profibus DP	Profibus distributed periphery
RS-232	Standard for a serial interface often available on computers (Recommended Standard 232)
RS-422	Interface standard for a wired differential serial data transfer (Recommended Standard 422)
RxD	Incoming data line (Received eXchange Data)
Rx+	Received data
Rx-	Received data
S GND	Signal ground
SHV	Connector assembly for coaxial cable (safe high voltage)
TPG	Total pressure measuring and control unit (total pressure gauge)
TxD	Outgoing data line (Transmitted eXchange Data)
Tx+	Transmission data
Tx-	Transmission data

Tbl. 3: Abbreviations used

1.4 Trademark proof

- Profibus® is a registered trade name of Profibus Nutzerorganisation e.V.
- Profibus® is a registered trade name of Profibus Nutzerorganisation e.V. (Profibus user organization).

2 Safety

2.1 General safety information

The following 4 risk levels and 1 information level are taken into account in this document.

⚠ DANGER
<p>Immediately pending danger</p> <p>Indicates an immediately pending danger that will result in death or serious injury if not observed.</p> <ul style="list-style-type: none"> ▶ Instructions to avoid the danger situation

⚠ WARNING
<p>Potential pending danger</p> <p>Indicates a pending danger that could result in death or serious injury if not observed.</p> <ul style="list-style-type: none"> ▶ Instructions to avoid the danger situation

⚠ CAUTION
<p>Potential pending danger</p> <p>Indicates a pending danger that could result in minor injuries if not observed.</p> <ul style="list-style-type: none"> ▶ Instructions to avoid the danger situation

NOTICE
<p>Danger of damage to property</p> <p>Is used to highlight actions that are not associated with personal injury.</p> <ul style="list-style-type: none"> ▶ Instructions to avoid damage to property

i	<p>Notes, tips or examples indicate important information about the product or about this document.</p>
----------	---------------------------------------------------------------------------------------------------------

2.2 Safety instructions

i	<p>Safety instructions according to product life stages</p> <p>All safety instructions in this document are based on the results of a risk assessment. Pfeiffer Vacuum has taken into account all the relevant life stages of the product.</p>
----------	-------------------------------------------------------------------------------------------------------------------------------------------------------------------------------------------------------------------------------------------------------

Risks during installation

⚠ DANGER
<p>Danger to life due to dangerous contact voltage</p> <p>Voltages above 30 V (AC) or 60 V (DC) are considered dangerous in accordance with EN 61010. If you come into contact with dangerous contact voltage, this can result in injury through electric shocks or even death.</p> <ul style="list-style-type: none"> ▶ Only connect the gauge to professionally grounded devices. ▶ Take additional safety measures on the system-side if processes in the vacuum system (e.g. flashovers) can result in dangerous voltages at the gauge connections. ▶ Secure the line to the gauge.

Risks when shipping**⚠ WARNING****Risk of poisoning from contaminated products**

Where products that contain harmful substances are shipped for maintenance or repair purposes, the health and safety of service personnel is at risk.

- ▶ Comply with the notices for safe shipment.

Risks during disposal**⚠ WARNING****Health hazard through poisoning from toxic contaminated components or devices**

Toxic process media result in contamination of devices or parts of them. During maintenance work, there is a risk to health from contact with these poisonous substances. Illegal disposal of toxic substances causes environmental damage.

- ▶ Take suitable safety precautions and prevent health hazards or environmental pollution by toxic process media.
- ▶ Decontaminate affected parts before carrying out maintenance work.
- ▶ Wear protective equipment.

2.3 Safety precautions

The product is designed according to the latest technology and recognized safety engineering rules. Nevertheless, improper use can result in danger to operator all third party life and limb, and product damage and additional property damage.

**Duty to provide information on potential dangers**

The product holder or user is obliged to make all operating personnel aware of dangers posed by this product.

Every person who is involved in the installation, operation or maintenance of the product must read, understand and adhere to the safety-related parts of this document.

**Infringement of conformity due to modifications to the product**

The Declaration of Conformity from the manufacturer is no longer valid if the operator changes the original product or installs additional equipment.

- Following the installation into a system, the operator is required to check and re-evaluate the conformity of the overall system in the context of the relevant European Directives, before commissioning that system.

General safety precautions when handling the product

- ▶ Observe all applicable safety and accident prevention regulations.
- ▶ Check that all safety measures are observed at regular intervals.
- ▶ Pass on safety instructions to all other users.
- ▶ Do not expose body parts to the vacuum.
- ▶ Always ensure a secure connection to the earthed conductor (PE).
- ▶ Never disconnect plug connections during operation.
- ▶ Observe the above shutdown procedures.
- ▶ Keep lines and cables away from hot surfaces (> 70 °C).
- ▶ Do not carry out your own conversions or modifications on the device.
- ▶ Observe the unit protection degree prior to installation or operation in other environments.
- ▶ Provide suitable touch protection, if the surface temperature exceeds 70 °C.
- ▶ Inform yourself about any contamination before starting work.

2.4 Proper use

The plug-in boards are analog measuring, interface and relay boards for the ModulLine total pressure measuring and control units TPG 300 and TPG 500.

- ▶ Install, operate and maintain the product only in accordance with these operating instructions.
- ▶ Comply with the limits of use.
- ▶ Observe the technical data.

2.5 Foreseeable improper use

Improper use of the product invalidates all warranty and liability claims. Any use that is counter to the purpose of the product, whether intentional or unintentional, is regarded as improper use; in particular:

- Use outside the limits of use specified in the technical data
- Use with corrosive or explosive media, if this is not explicitly permitted
- Use outdoors
- Use after technical changes (inside or outside on the product)
- Use with replacement or accessory parts that are not suitable or not approved

3 Product description

3.1 Function

3.1.1 Pirani measurement system

The heat conductivity of gases is pressure-dependent within certain limits. This physical occurrence is utilized in the Pirani thermal conductivity vacuum gauge to measure the pressure. A thin wolfram wire with high temperature coefficients is used as the measuring element. With a suitable control circuit, the resistance of the wire and thus its temperature are kept constant. The electrical power that is fed to the wire is a measure for the heat power dissipated in the gas through heat conduction and therefore a measure of the pressure.

3.1.2 Cold cathode measuring system

The current that flows into a self-sustaining gas discharge with cold cathode (similar to Penning) depends on the applied voltage, the composition of the gas and the pressure. A magnetic field penetrates into the measuring room that causes the electrons on the spiral trajectories to move from the cathode towards the anode, and as a result perform a sufficient number of ionizing impacts to maintain the discharge, even with low gas density. If the anode voltage and magnetic field are now kept constant (with known gas type), the discharge current is a measure for the pressure.

3.2 Identifying the product

You will need all the data from the rating plate to safely identify the product when communicating with Pfeiffer Vacuum.

- ▶ To ensure clear identification of the product when communicating with Pfeiffer Vacuum, always keep all of the information on the rating plate to hand.

3.3 Structure of plug-in boards

3.3.1 Pirani measurement boards

When the total pressure measuring and control unit is switched on, the Pirani measuring circuits are always in operation. The analog signals are always available, irrespective of the pressure display.

Pirani measurement boards have:

- 2 independent fine vacuum measuring circuits, each with
 - 1 gauge power supply plug
 - 2 calibration potentiometers
 - 1 analog signal output

3.3.2 Cold cathode measurement boards

When the gauge is switched on, the analog signals are always available, irrespective of the pressure display. This measurement board has special electronics that limit the measurement current to 100 μA . This results in a considerably longer service life for the gauges.

Cold cathode measurement boards for high vacuum have:

- 2 measuring circuits, each with
 - 1 gauge power supply plug
 - 1 analog signal output ("CONTROL" connection)
 - 1 control input ("CONTROL" connection)

3.3.3 Pirani/cold cathode measurement boards

These measuring boards are available with three different measuring ranges: 10^{-9} hPa, 10^{-10} hPa and 10^{-11} hPa. The measurement boards for the range 10^{-10} hPa (CP 300 C10) and 10^{-11} hPa (CP 300 T11 and CP 300 T11L) have special electronics that limit the measurement current to 100 μA . This results in a considerably longer service life for the gauges.

Pirani/cold cathode measurement boards have:

- 1 Pirani measuring circuit with
 - 1 gauge power supply plug
 - 2 calibration potentiometers
 - 1 analog signal output
- 1 cold cathode measuring circuit with
 - 1 gauge power supply plug
 - 1 analog signal output

3.3.4 Interface and relay boards

There are 5 interface and relay boards available:

- 2 interface and relay boards with RS-232-C interfaces
- 1 interface and relay board with RS-422 interface
- 1 interface and relay board with Profibus-DP interface
- 1 interface board with Profinet interface

All interface and relay boards each have 5 relays with potential-free switching contacts. The interface and relay cards have different switching voltages for the relays and different interface connections.

3.4 Interfaces

3.4.1 "OUTPUT" connection on PI 300 and CP 300

Each measuring circuit has an analog signal output. Suitable plugs are included with each measurement board.

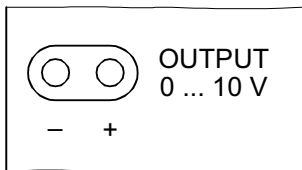

Fig. 1: "OUTPUT" connection with 2 sockets

3.4.2 "CONTROL" connection on PE 300 DC9

Each measuring circuit has a control input as well as an analog signal output. A suitable plug is included with each measurement board.

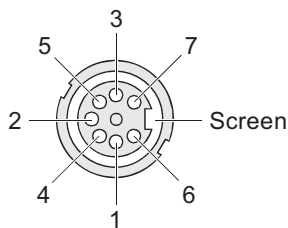

Fig. 2: "CONTROL" connection on PE 300 DC9

- | | |
|--------------------|-----------------------|
| 1 Analog GND IKR 1 | 5 IKR ON 2 |
| 2 Digital GND | 6 Analog Output IKR 1 |
| 3 Analog GND IKR 2 | 7 Analog Output IKR 2 |
| 4 IKR ON 1 | Screen Screen |

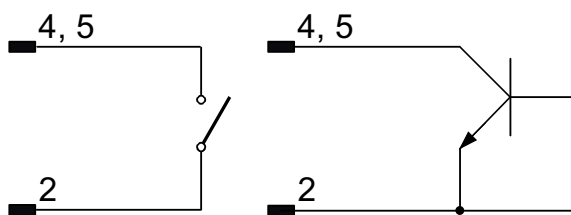

Fig. 3: Switch and logic on the "CONTROL" connection

3.4.3 "RELAY" connection on IF 300A/C/P

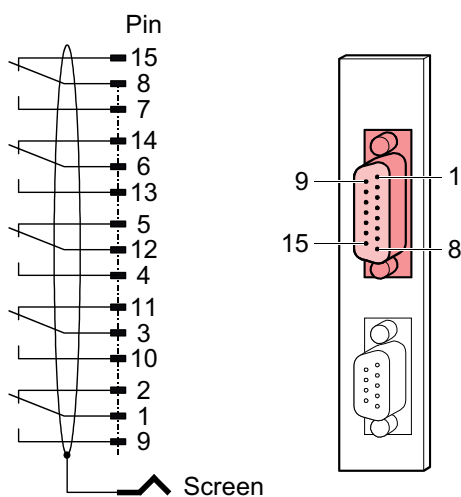

Fig. 4: "RELAY" connection on IF 300A/C/P

The figure shows the contacts in rest position.

Pins			Designation	Switching function
15	8	7	Relay 1	1
14	6	13	Relay 2	2
5	12	4	Relay 3	3
11	3	10	Relay 4	4
2	1	9	Relay 5	Error status

Tbl. 4: Switch functions on IF 300A/C/P

3.4.4 "RELAY" connection on IF 300B

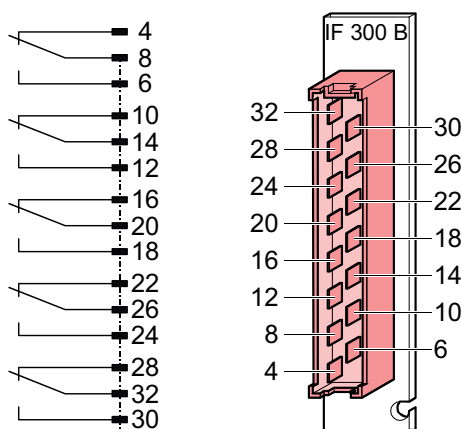

Fig. 5: "RELAY" connection on IF 300B

The figure shows the contacts in rest position.

Pins			Designation	Switching function
4	8	6	Relay 1	1
10	14	12	Relay 2	2
16	20	18	Relay 3	3
22	26	24	Relay 4	4
28	32	30	Relay 5	Error status

Tbl. 5: Switching functions on IF 300B

3.4.5 "RS-232" connection on IF 300A

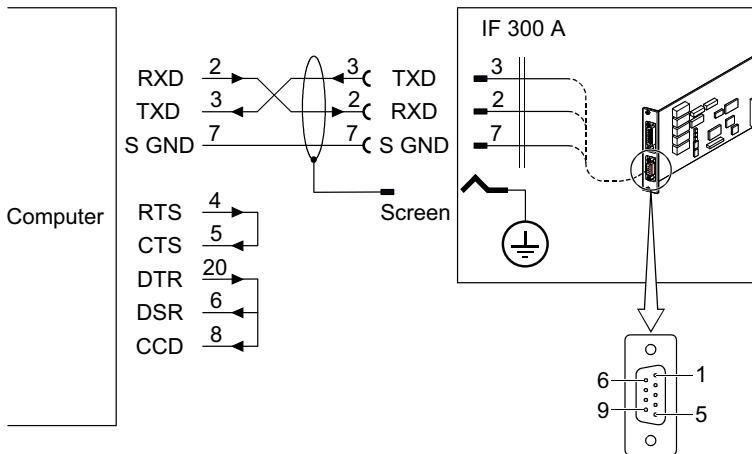

Fig. 6: "RS-232" connection on IF 300A

- 2 Receive data (RxD) (relating to the measuring device)
- 3 Transmit data (TxD) (relating to the measuring device)
- 7 Signal ground (S GND)

3.4.6 "RS-232" connection on IF 300B

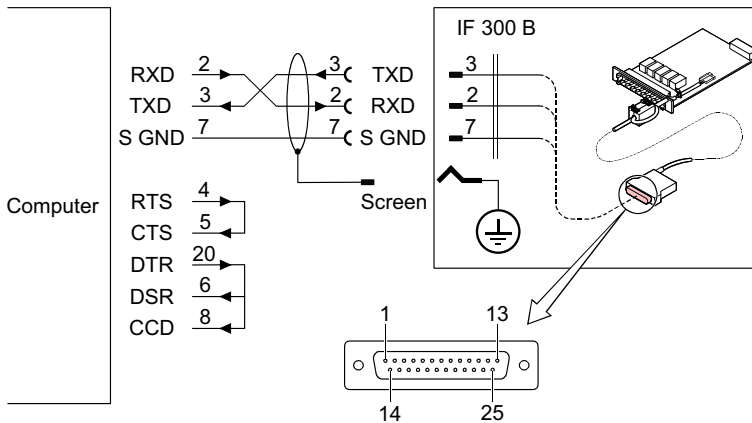

Fig. 7: "RS-232" connection on IF 300B

- 2 Receive data (RxD) (relating to the measuring device)
- 3 Transmit data (TxD) (relating to the measuring device)
- 7 Signal ground (S GND)

3.4.7 "RS-422" connection on IF 300C

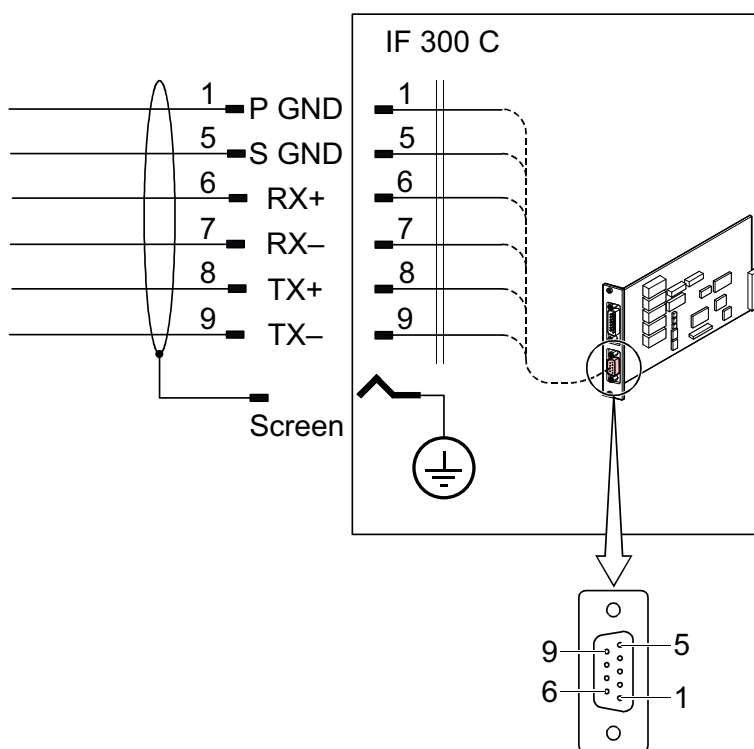

Fig. 8: "RS-422" connection on IF 300C

1	Protective ground (P GND)	7	Reception data (Rx-) (relating to the measuring device)
2, 3, 4	unassigned	8	Transmission data (Tx+) (relating to the measuring device)
5	Signal ground (S GND)	9	Transmission data (Tx-) (relating to the measuring device)
6	Reception data (Rx+) (relating to the measuring device)	Gehäuse (Screen)	Screen

3.4.8 "Profibus" connection on IF 300P



Details on the Profibus-DP interface

You can find details on the Profibus-DP interface in the corresponding communication protocol.

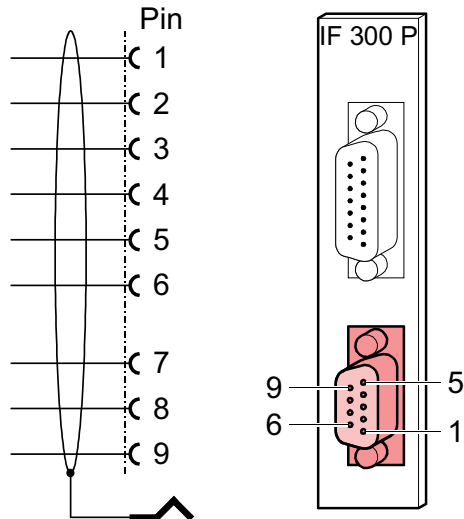

Fig. 9: "Profibus" connection on IF 300P

- | | |
|----------------------|-------------------------------------------|
| 1 Screen | 6 VP (only required with bus end devices) |
| 2 Do not connect | 7 Do not connect |
| 3 RxD/TxD-P (Line B) | 8 RxD/TxD-N (Line A) |
| 4 CNTR-P (optional) | 9 Do not connect |
| 5 DGND | |

3.4.9 "Profinet" connection on IF 500 PN



Details on Profinet interface

You can find details on the Profinet interface in the corresponding communication instructions.

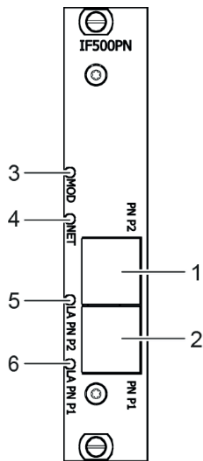

Fig. 10: "Profinet" connection on IF 500 PN

- | | |
|----------------------------|---------------------------------|
| 1 Profinet port 2 (output) | 4 LED network status (NET) |
| 2 Profinet port 1 (input) | 5 LED Profinet status on port 2 |
| 3 LED module status (MOD) | 6 LED Profinet status on port 1 |

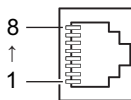

Fig. 11: "RJ-45" connection on IF 500 PN

- | | |
|---------------------------|------------------------|
| 1 Transmission data (Tx+) | 6 Reception data (Rx-) |
| 2 Transmission data (Tx-) | 4, 5, 7, 8 unassigned |
| 3 Reception data (Rx+) | |

3.5 Scope of delivery

The scope of delivery includes the following parts:

- Plug-in board
- Plugs for analog signals
- Folding ferrite (for IF 300B)
- Operating instructions

Unpacking the product and checking completeness of the shipment

1. Unpack the product.
2. Remove the transport fasteners, transport protection etc.
3. Store the transport fasteners, transport protection etc. in a safe place.
4. Check that the shipment is complete.
5. Ensure that no parts are damaged.

4 Transport and storage

4.1 Transporting product

NOTICE

Damage caused by incorrect transport

Transport in unsuitable packaging or failure to install all transport locks can result in damage to the product.

- ▶ Comply with the instructions for safe transport.

NOTICE

Damage to unit from electrostatic discharge

Electrostatic discharge damages electronic components. Defects resulting from failure to comply with this warning shall result in loss of any warranty claim entitlement.

- ▶ Carry out all work on ESD-protected workstations only, in compliance with the appropriate working methods.
- ▶ When the unit is open, take suitable precautions against electrostatic charges.
- ▶ Always store electronic units and components in anti-static packaging.
- ▶ Observe EN 61340, Parts 5-1 and 5-2 – Protection of electronic devices from electrostatic phenomena.



Packing

We recommend keeping the transport packaging and original protective cover.

Transport product safely

- ▶ Observe the weight specified on the transport packaging.
- ▶ Where possible, always transport or ship the product in the original transport packaging.
- ▶ Always use dense and impact-proof transport packaging for the product.
- ▶ Remove the existing protective cover and transport protections only immediately prior to installation.
- ▶ Reattach transport locks and transport protections prior to each transport.

4.2 Storing product

NOTICE

Damage caused by improper storage

Improper storage will lead to damage to the product.

Static charging, moisture, etc. will lead to defects on the electronic components.

- ▶ Comply with the instructions for safe storage.



Packing

We recommend storing the product in its original packaging.

Store product safely

- ▶ Store the product in a cool, dry, dust-free place, where it is protected against impacts and mechanical vibration.
- ▶ Always use dense and impact-proof packaging for the product.
- ▶ Where possible, store the product in its original packaging.
- ▶ Store electronic components in antistatic packaging.
- ▶ Maintain the permissible storage temperature.
- ▶ Avoid extreme fluctuations of the ambient temperature.
- ▶ Avoid high air humidity.

- ▶ Seal connections with the original protective caps.
- ▶ Protect the product with the original transport protection (where available).

5 Installation

5.1 Installing/removing plug-in boards

NOTICE

Damage to unit from electrostatic discharge

Electrostatic discharge damages electronic components. Defects resulting from failure to comply with this warning shall result in loss of any warranty claim entitlement.

- ▶ Carry out all work on ESD-protected workstations only, in compliance with the appropriate working methods.
- ▶ When the unit is open, take suitable precautions against electrostatic charges.
- ▶ Always store electronic units and components in anti-static packaging.
- ▶ Observe EN 61340, Parts 5-1 and 5-2 – Protection of electronic devices from electrostatic phenomena.



Dummy plates for free slots

Always cover the free slots on the total pressure measuring and control unit with dummy plates for safety reasons.

Suitable dummy plates are available as accessories.

Required tools

- Flat-tip screwdriver

Accessories required

- Dummy plates, if free slots are available on the TPG.

Procedure

1. Switch the TPG off.
2. Wait at least 1 minute.
3. Disconnect all cable connections, except the mains cable of the TPG.
4. Afterwards, connect the mains cable of the TPG.
5. Unscrew the dummy plate/plug-in board.
6. Remove the dummy plate/plug-in board from the TPG.
7. Carefully insert the plug-in board into the TPG.
8. Carefully tighten the plug-in board.
 - If plug-in board screws are loose, trouble-free operation cannot be guaranteed.
9. Connect the mains cable back onto the TPG.
10. Re-establish all other cable connections to the TPG.
11. Switch the TPG back on again.

5.2 Connecting gauges

5.2.1 Connecting Pirani gauges

⚠ DANGER

Danger to life due to dangerous contact voltage

Voltages above 30 V (AC) or 60 V (DC) are considered dangerous in accordance with EN 61010. If you come into contact with dangerous contact voltage, this can result in injury through electric shocks or even death.

- ▶ Only connect the gauge to professionally grounded devices.
- ▶ Take additional safety measures on the system-side if processes in the vacuum system (e.g. flashovers) can result in dangerous voltages at the gauge connections.
- ▶ Secure the line to the gauge.

Procedure

1. Make sure that the TPG is switched off.
2. Despite being partially screened, do not lay the gauge cable parallel with cables with too much interference.
3. Connect the gauge with the measuring cable to the "IKR" connection on the measurement board.
4. Lock the plug to prevent unintentional disconnection.

5.2.2 Connecting the cold cathode gauge**⚠ DANGER****Danger to life due to dangerous contact voltage**

Voltages above 30 V (AC) or 60 V (DC) are considered dangerous in accordance with EN 61010. If you come into contact with dangerous contact voltage, this can result in injury through electric shocks or even death.

- ▶ Only connect the gauge to professionally grounded devices.
- ▶ Take additional safety measures on the system-side if processes in the vacuum system (e.g. flashovers) can result in dangerous voltages at the gauge connections.
- ▶ Secure the line to the gauge.

**Maximum length of coax cables**

The maximum length of 100 m for coax cables applies for compliance with EN 61010. Longer lengths are not permitted without additional safety measures.

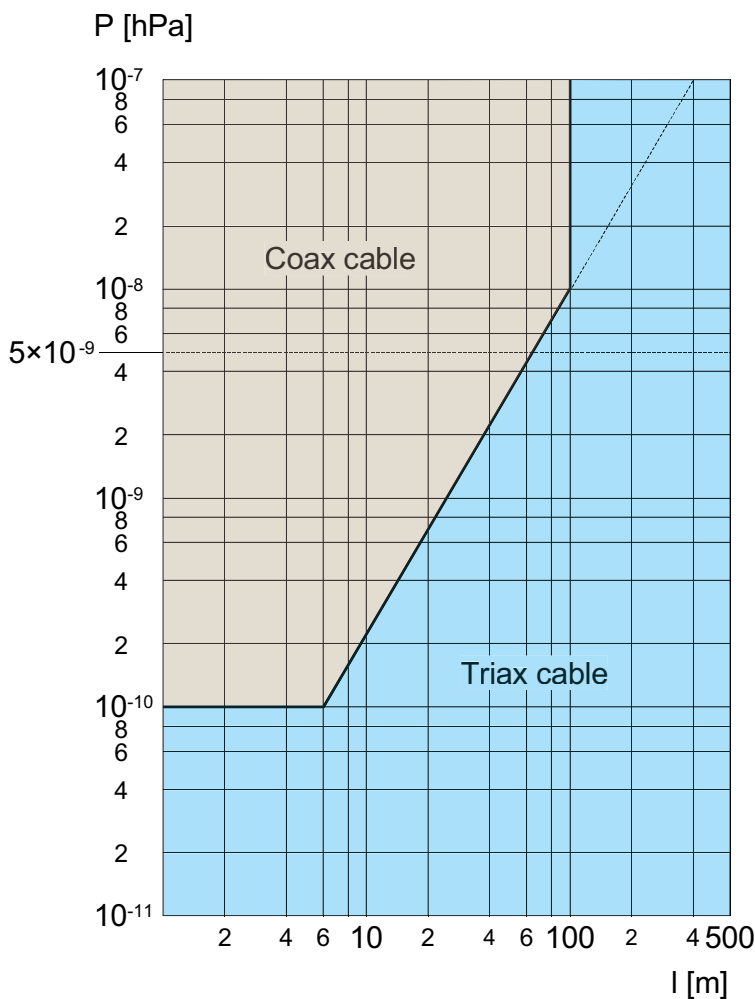

Fig. 12: Coax cable and triax cable

Required tool

- With triax cable: Open-end wrench (17 mm WAF)

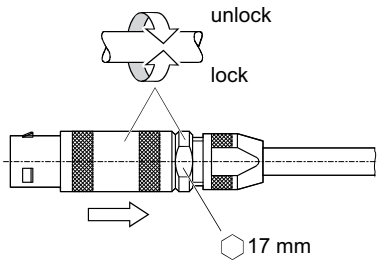

Fig. 13: Locking the triax plug

Procedure

1. Make sure that the TPG is switched off.
2. Despite being partially screened, do not lay the gauge cable parallel with cables with too much interference.
3. Choose the suitable measuring cable type in accordance with Figure "Coax cable and triax cable".
4. Connect the gauge with the measuring cable to the "IKR" connection on the measurement board.
5. With triax cable: Lock the triax plug to prevent unintentional disconnection, loosening and touching of the inner conductor.
6. Additionally, ground the gauge if the gauge is not grounded via the recipients.

5.3 Connecting interfaces and connections

5.3.1 Connecting the analog signal to the measurement boards

Procedure

1. Only use screened cable.
2. Connect the screen to the plug sleeve.
3. If you ground both ends of the screen you prevent the occurrence of compensating currents (e.g. when connecting all devices involved to the same mains distributor).
4. Make sure that components to be connected externally contain the technical data of the plug-in board.
5. Connect the analog signal to the plugs included with the plug-in board.

5.3.2 Connecting relays to the interface boards

Connecting relays (IF 300A/C/P)

1. Only carry out work on the plug when it is de-energized.
2. Make sure that components to be connected externally contain the technical data of the plug-in board.
3. Connect the relay with the relay plug.

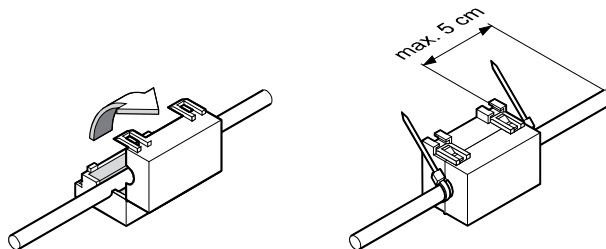

Fig. 14: Folding ferrite for IF 300B



Insulated flat pin terminals for IF 300B

With voltages < 50 V, you may use 4.8 × 0.8 mm insulated flat pin terminals. However, Pfeiffer Vacuum recommends using the relay plug, as the relay plug enables fast disconnection of the connection as well as strain relief.

Connecting relays (IF 300B)

Screened cable is not required for the connection.

1. Only carry out work on the plug when it is de-energized.
2. In general, use the relay plug for voltages ≥ 50 V for safety reasons.
3. Make sure that components to be connected externally contain the technical data of the plug-in board.
4. Mount the folding ferrite in order to prevent electromagnetic interference.
 - The folding ferrite is included in the scope of delivery.
5. Maintain a distance of max. 5 cm between the folding ferrite and the relay plug.
6. Connect the relay to the relay plug or insulated flat pin terminals.

5.3.3 Connecting "RS-232-C" interface of IF 300A

Procedure

1. Only use screened cable.
2. Connect the screen to the plug sleeve.
3. If you ground both ends of the screen you prevent the occurrence of compensating currents (e.g. when connecting all devices involved to the same mains distributor).
4. Make sure that components to be connected externally contain the technical data of the plug-in board.
5. Use a suitable interface cable to connect the interface.

5.3.4 Connecting "RS-232-C" interface of IF 300B

Accessories required

- Interface cable, for IF 300 B, RS-232-C, 0.4 m

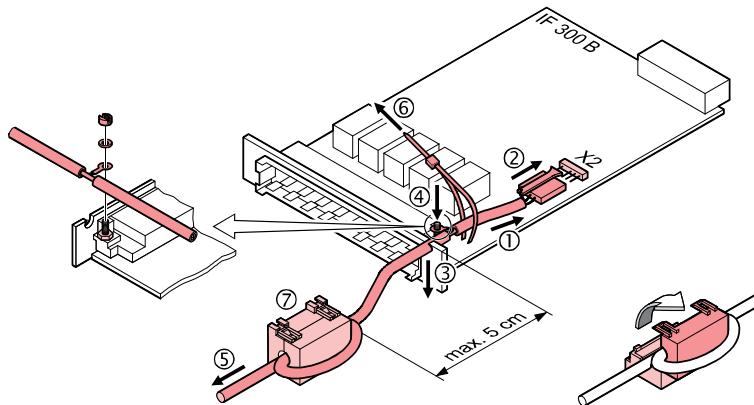

Fig. 15: Connecting interface cable to IF 300B

Procedure

1. Guide the interface cable to connection "X2" on the interface board.
2. Fasten the plug of the interface cable to connection "X2" on the circuit board.
3. Connect the interface cable in the front plate of the interface board.
4. Tighten the interface cable using the fastening parts.
5. Pull the interface cable through the folding ferrite.
 - The folding ferrite is included in the scope of delivery.
6. Secure the interface cable to the circuit board using the cable tie.
7. Mount the folding ferrite in order to prevent electromagnetic interference.
8. Maintain a distance of max. 5 cm between the folding ferrite and the front plate.

5.3.5 Connecting "RS-422" interface of IF 300 C

Procedure

1. Only use screened cable.
2. Connect the screen to the plug sleeve.
3. If you ground both ends of the screen you prevent the occurrence of compensating currents (e.g. when connecting all devices involved to the same mains distributor).

4. Make sure that components to be connected externally contain the technical data of the plug-in board.
5. Use a suitable interface cable to connect the interface.

5.3.6 Connecting "Profibus-DP" interface of IF 300 P



Details on the Profibus-DP interface

You can find details on the Profibus-DP interface in the corresponding communication protocol.

Procedure

1. Only use the special cable provided.
2. Make sure that components to be connected externally contain the technical data of the plug-in board.
3. Connect the interface using the special cable.

5.3.7 Connecting "Profinet" interface of IF 500 PN



Details on Profinet interface

You can find details on the Profinet interface in the corresponding communication instructions.

Procedure

1. Only use the special cable provided.
2. Make sure that components to be connected externally contain the technical data of the plug-in board.
3. Connect the cable of the "OUT" port of the upstream device to port 1 (input) of the IF 500 PN.
4. Connect the cable from port 2 (output) of the IF 500 PN to the "IN" port of the next device.

6 Operation

Switching measuring circuit on or off externally (PE 300 DC9)

- ▶ First switch the gauge on manually or automatically if you want to control the gauge via the external input.
- ▶ Switch the measuring circuit on or off using one of the three options.
 - manual
 - automatic
 - external, via a contact on the "CONTROL" connection

7 Calibrating Pirani measuring circuit



Maintenance in the Pfeiffer Vacuum Service Center

Pfeiffer Vacuum offers a complete maintenance service for all products.

Pfeiffer Vacuum recommends: Contact your Pfeiffer Vacuum Service Center to arrange the maintenance of defective products and components.

Operation in other climatic conditions, long-term operation, extreme temperatures, a different mounting orientation, aging or contamination lead to a zero point shift in the Pirani measuring circuit. A zero point shift will necessitate recalibration or cleaning.

Pfeiffer Vacuum has calibrated the gauge to standard values at the factory. However, as a result of individual scattering, gauge tolerances, gauge contamination or different cable lengths, you must accept deviations. You can compensate these factors with 2 trimming potentiometers in certain limits. You do not need to calibrate cold cathode measuring circuits.

Required tools

- Slot screwdriver

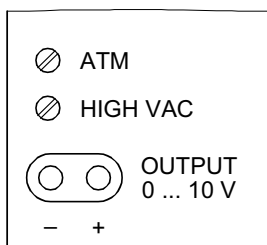

Fig. 16: ATM and HIGH VAC trimming potentiometers

Preparing for calibration

1. Ensure the same installation and ambient conditions as those applicable for normal use.
2. Start up the gauge.

HV calibration

1. Operate the gauge (for at least 10 minutes) until the gauge has reached the operating temperature.
2. Evacuate the vacuum system to pressure $< 10^{-4}$ hPa.
3. Select the measuring circuit you wish to calibrate on the TPG.
 - You can find further information on the "Sensor" mode in the TPG operating instructions.
4. Rotate the "HIGH VAC" trimming potentiometer until the pressure 8.0×10^{-4} hPa appears on the TPG display.
5. Rotate the "HIGH VAC" trimming potentiometer around a 1/4 of a turn in an anticlockwise direction.
 - An underrange "ur 10⁻⁴" appears on the TPG display.

ATM calibration

1. Operate the gauges for at least 10 minutes at atmospheric pressure.
2. Select the measuring circuit you wish to calibrate on the TPG.
 - You can find further information on the "Sensor" mode in the TPG operating instructions.
3. Rotate the "ATM" trimming potentiometer until the pressure 1.0×10^3 hPa appears on the TPG display.
4. Evacuate the vacuum system to pressure $< 10^{-4}$ hPa.
5. Check the high vacuum value.
6. Adjust the high vacuum value if necessary.

8 Malfunctions



Warranty

Malfunctioning of the equipment as a direct result of contamination or wear, as well as wear parts, is not covered by the warranty.

Malfunction	Possible cause	Remedy
Gauge cable will not connect to IKR gauge.	Old IKR gauge with MHV plug	Use a correct cable.
		Change the plug.
Gauge cable will not connect with measurement board.	Gauge cable has old plug	Use a correct cable.
		1. Disconnect the plug. 2. Replace the plug.

Tbl. 6: Disturbances during installation

Malfunction	Possible cause	Remedy
Pirani display too high	Pirani gauge contaminated	Calibrate the Pirani measuring circuit.
		Clean the gauge.
		Replace the gauge.
Cold cathode display too high	Plug insulation is contaminated or damp	Clean the insulation.
		Replace the plug.
	Air humidity (leakage current)	Keep the air humidity level low. Keep the gauge in continuous operation.
Cold cathode display too low	Cold cathode gauge contaminated	Clean the gauge.
Pirani will not calibrate.	Incorrect combination: Measurement board - gauge - cable	Choose the correct combination.
	Gauge too contaminated	Clean the gauge.
		Replace the gauge.

Tbl. 7: Interference during operation and calibration

Malfunction	Possible cause	Remedy
Cold cathode permanently displays OR (overrange), although the pressure is within the measurement range.	Short circuit cold cathode cable/gauge	Repair the cable/gauge.
		Replace the cable/gauge.
	Cold cathode measurement board defective	Replace the cold cathode measurement board.
Cold cathode permanently displays U (underrange), although the pressure is within the measurement range.	No IKR gauge connected	Connect a gauge.
	Interruption cold cathode cable	Repair the cable.
		Replace the cable.
	Cold cathode gauge failed	Replace the gauge.
Cold cathode measurement board defective	Replace the cold cathode measurement board.	

Tbl. 8: Disturbances as a result of defects

Malfunction	Possible cause	Remedy
No communication	Pins 2 and 3 of interface cable not crossed	Use a correct cable.
	Incorrect baud rate	Adjust the baud rate.
	Incorrect data format	Maintain the data format in accordance with the data in the TPG basic unit.

Tbl. 9: Disturbances with the RS-232-C interface

Malfunction	Possible cause	Remedy
No communication	Incorrect baud rate	Adjust the baud rate.
	Incorrect data format	Maintain the data format in accordance with the data in the TPG basic unit.

Tbl. 10: Disturbances with the RS-422 interface

Malfunction	Possible cause	Remedy
No communication	Incorrect baud rate set ¹⁾	Set the correct baud rate (19200 baud).
	Incorrect data format	Observe the Profibus-DP communication instructions.
Cycle time > 100 ms	Incorrect firmware	Check the firmware: <ul style="list-style-type: none"> • TPG 300 firmware: 302-654 • TPG 500 firmware: V010100 • Profibus firmware: V1.5
	Incorrect baud rate set ²⁾	Set the correct baud rate (19200 baud).

Tbl. 11: Disturbances with the Profibus-DP interface

Malfunction	Possible cause	Remedy
No communication	Incorrect firmware	Check the firmware: <ul style="list-style-type: none"> • TPG 300 firmware: not supported • TPG 500 firmware: V010300 • Profinet firmware: V010100

Tbl. 12: Disturbances with the Profinet interface

1) On TPG 300 basic unit, from firmware 302-654.

2) On TPG 300 basic unit, from firmware 302-654.

9 Shipping

WARNING

Risk of poisoning from contaminated products

Where products that contain harmful substances are shipped for maintenance or repair purposes, the health and safety of service personnel is at risk.

- ▶ Comply with the instructions for safe distribution.



Decontamination subject to charge

Pfeiffer Vacuum decontaminates products not clearly declared "Free of contamination" at your expense.

Ship product safely

- ▶ Do not ship microbiological, explosive or radioactively contaminated products.
- ▶ Observe the shipping guidelines for the participating countries and transport companies.
- ▶ Highlight any potential dangers on the outside of the packaging.
- ▶ Download the explanation for contamination at [Pfeiffer Vacuum Service](#).
- ▶ Always enclose a completed declaration of contamination.

10 Recycling and disposal

WARNING

Health hazard through poisoning from toxic contaminated components or devices

Toxic process media result in contamination of devices or parts of them. During maintenance work, there is a risk to health from contact with these poisonous substances. Illegal disposal of toxic substances causes environmental damage.

- ▶ Take suitable safety precautions and prevent health hazards or environmental pollution by toxic process media.
- ▶ Decontaminate affected parts before carrying out maintenance work.
- ▶ Wear protective equipment.



Environmental protection

You **must** dispose of the product and its components in accordance with all applicable regulations for protecting people, the environment and nature.

- Help to reduce the wastage of natural resources.
- Prevent contamination.

10.1 General disposal information

Pfeiffer Vacuum products contain materials that you must recycle.

- ▶ Dispose of our products according to the following:
 - Iron
 - Aluminium
 - Copper
 - Synthetic
 - Electronic components
 - Oil and fat, solvent-free
- ▶ Observe the special precautionary measures when disposing of:
 - Fluoroelastomers (FKM)
 - Potentially contaminated components that come into contact with media

10.2 Disposing of plug-in boards

Pfeiffer Vacuum plug-in boards contain materials that you must recycle.

1. Separate the components into recyclable materials.
2. Recycle the components.
3. Dispose of the product or components in a safe manner according to locally applicable regulations.

11 Service solutions by Pfeiffer Vacuum

We offer first-class service

High vacuum component service life, in combination with low downtime, are clear expectations that you place on us. We meet your needs with efficient products and outstanding service.

We are always focused on perfecting our core competence – servicing of vacuum components. Once you have purchased a product from Pfeiffer Vacuum, our service is far from over. This is often exactly where service begins. Obviously, in proven Pfeiffer Vacuum quality.

Our professional sales and service employees are available to provide you with reliable assistance, worldwide. Pfeiffer Vacuum offers an entire range of services, from [original replacement parts](#) to [service contracts](#).

Make use of Pfeiffer Vacuum service

Whether preventive, on-site service carried out by our field service, fast replacement with mint condition replacement products, or repair carried out in a [Service Center](#) near you – you have various options for maintaining your equipment availability. You can find more detailed information and addresses on our homepage, in the [Pfeiffer Vacuum Service](#) section.

You can obtain advice on the optimal solution for you, from your [Pfeiffer Vacuum representative](#).

For fast and smooth service process handling, we recommend the following:



1. Download the up-to-date form templates.
 - [Explanations of service requests](#)
 - [Service requests](#)
 - [Contamination declaration](#)



- a) Remove and store all accessories (all external parts, such as valves, protective screens, etc.).
 - b) If necessary, drain operating fluid/lubricant.
 - c) If necessary, drain coolant.
2. Complete the service request and contamination declaration.



3. Send the forms by email, fax, or post to your local [Service Center](#).



4. You will receive an acknowledgment from Pfeiffer Vacuum.

PFEIFFER VACUUM

Submission of contaminated products

No microbiological, explosive, or radiologically contaminated products will be accepted. Where products are contaminated, or the contamination declaration is missing, Pfeiffer Vacuum will contact you before starting service work. Depending on the product and degree of pollution, **additional decontamination costs** may be incurred.

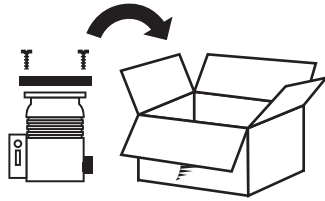

5. Prepare the product for transport in accordance with the provisions in the contamination declaration.
 - a) Neutralize the product with nitrogen or dry air.
 - b) Seal all openings with blind flanges, so that they are airtight.
 - c) Shrink-wrap the product in suitable protective foil.
 - d) Package the product in suitable, stable transport containers only.
 - e) Maintain applicable transport conditions.

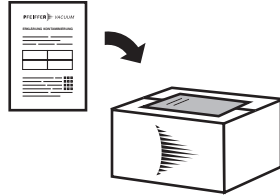

6. Attach the contamination declaration to the **outside** of the packaging.

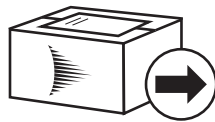

7. Now send your product to your local Service Center.

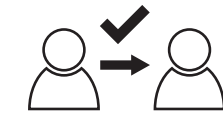

8. You will receive an acknowledgment/quotation, from Pfeiffer Vacuum.

PFEIFFER VACUUM

Our sales and delivery conditions and repair and maintenance conditions for vacuum devices and components apply to all service orders.

12 Accessories



View the [range of accessories for ModuLine](#) on our website.

12.1 Accessory information

Measuring boards

For the connection of Pirani gauges (TPR) and cold cathode gauges (IKR) for measuring atmospheric pressure (TPR) up to UHV (IKR)

Interface boards

Serial and fieldbus interfaces with switchpoints with contacts of varying loading capacity

Measurement cable and extension measurement cable

Measurement cable in standard and high temperature versions in different lengths, for connecting to a Pfeiffer Vacuum total pressure measuring and control unit or an ionization measuring device

Dummy plates

Cover plate for free slots on Pfeiffer Vacuum total pressure measuring and control units that are not fully configured

12.2 Ordering accessories

Description	Order number	suitable for measurement boards
Pirani gauge TPR 010, DN 10 ISO-KF	PT R02 270	PI 300 D, CP 300 C9, CP 300 C10, CP 300 T11, CP 300 T11L
Pirani gauge TPR 017, non-corrosive, DN 16 ISO-KF	PT R13 270	PI 300 DN
Pirani gauge TPR 017, non-corrosive, DN 16 CF-F	PT R13 271	PI 300 DN
Pirani gauge TPR 018, DN 16 ISO-KF	PT R15 010	PI 300 D, CP 300 C9, CP 300 C10, CP 300 T11, CP 300 T11L
Pirani gauge TPR 018, DN 16 CF-F	PT R15 011	PI 300 D, CP 300 C9, CP 300 C10, CP 300 T11, CP 300 T11L
Pirani gauge TPR 018, DN 40 CF-F	PT R15 014	PI 300 D, CP 300 C9, CP 300 C10, CP 300 T11, CP 300 T11L

Tbl. 13: Pirani gauges

Description	Order number	suitable for measurement boards
Cold cathode gauge IKR 050, coaxial, FPM-sealed, DN 25 ISO-KF	PT R18 500	PE 300 DC9, CP 300 C9, CP 300 C10
Cold cathode gauge IKR 050, coaxial, FPM-sealed, DN 40 ISO-KF	PT R18 501	PE 300 DC9, CP 300 C9, CP 300 C10
Cold cathode gauge IKR 050, coaxial, FPM-sealed, DN 40 CF-F	PT R18 502	PE 300 DC9, CP 300 C9, CP 300 C10
Cold cathode gauge IKR 060, coaxial, metal seal, DN 40 ISO-KF	PT R18 753	PE 300 DC9, CP 300 C9, CP 300 C10
Cold cathode gauge IKR 060, coaxial, metal seal, DN 40 CF-F	PT R18 751	PE 300 DC9, CP 300 C9, CP 300 C10
Cold cathode gauge IKR 070, triaxial, metal seal, DN 40 ISO-KF	PT R20 501	CP 300 T11, CP 300 T11L
Cold cathode gauge IKR 070, triaxial, metal seal, DN 40 CF-F	PT R20 502	CP 300 T11, CP 300 T11L

Tbl. 14: Cold cathode gauges



Measuring and extension cable

The cable is available in a standard version for temperatures up to max. 80 °C and as a high temperature table for temperatures up to 250 °C.

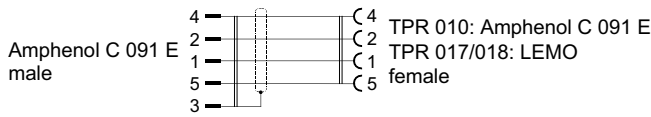

Fig. 17: Pirani measuring cable connection diagram

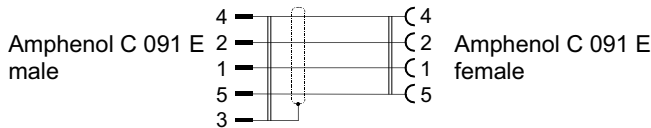

Fig. 18: Pirani extension cable connection diagram

Description	Order number
Measuring cable, TPR 010, 2.0 m, 80 °C	PT 548 401 -T
Measuring cable, TPR 010, 3.0 m, 80 °C	PT 548 402 -T
Measuring cable, TPR 010, 6.0 m, 80 °C	PT 548 403 -T
Measuring cable, TPR 010, 10 m, 80 °C	PT 548 450 -T
Measuring cable, TPR 010, 15 m, 80 °C	PT 548 451 -T
Measuring cable, TPR 010, 20 m, 80 °C	PT 548 452 -T
Measuring cable, TPR 010, 25 m, 80 °C	PT 548 453 -T
Measuring cable, TPR 010, 30 m, 80 °C	PT 548 415 -T
Measuring cable, TPR 010, 35 m, 80 °C	PT 548 454 -T
Measuring cable, TPR 010, 40 m, 80 °C	PT 548 416 -T
Measuring cable, TPR 010, 45 m, 80 °C	PT 548 455 -T
Measuring cable, TPR 010, 50 m, 80 °C	PT 548 417 -T

Tbl. 15: Measuring cable for TPR 010

Description	Order number
Measuring cable TPR 017/018, 3.0 m, 80 °C	PT 548 308 -T
High temperature measuring cable TPR 017/018, 3.0 m, 250 °C	PT 548 414 -T
Measuring cable TPR 017/018, 6.0 m, 80 °C	PT 548 309 -T
High temperature measuring cable TPR 017/018, 6.0 m, 250 °C	PT 548 465 -T
Measuring cable TPR 017/018, 10 m, 80 °C	PT 548 456 -T
High temperature measuring cable TPR 017/018, 10 m, 250 °C	PT 448 047 -T
Measuring cable TPR 017/018, 15 m, 80 °C	PT 548 457 -T
High temperature measuring cable TPR 017/018, 15 m, 250 °C	PT 448 043 -T
Measuring cable TPR 017/018, 20 m, 80 °C	PT 548 458 -T
High temperature measuring cable TPR 017/018, 20 m, 250 °C	PT 448 044 -T
Measuring cable TPR 017/018, 25 m, 80 °C	PT 548 459 -T
Measuring cable TPR 017/018, 30 m, 80 °C	PT 548 460 -T
Measuring cable TPR 017/018, 35 m, 80 °C	PT 548 461 -T
Measuring cable TPR 017/018, 40 m, 80 °C	PT 548 462 -T
Measuring cable TPR 017/018, 45 m, 80 °C	PT 548 463 -T
Measuring cable TPR 017/018, 50 m, 80 °C	PT 548 464 -T

Tbl. 16: Measuring cable for TPR 017 and TPR 018

Description	Order number
Extension measuring cable, TPR 010/017/018, 10 m, 80 °C	PT 548 466 -T
Extension measuring cable, TPR 010/017/018, 20 m, 80 °C	PT 548 468 -T
Extension measuring cable, TPR 010/017/018, 30 m, 80 °C	PT 548 470 -T
Extension measuring cable, TPR 010/017/018, 40 m, 80 °C	PT 548 472 -T
Extension measuring cable, TPR 010/017/018, 50 m, 80 °C	PT 548 474 -T

Tbl. 17: Extension cable for TPR 010, TPR 017 and TPR 018

Description	Order number
Measuring cable IKR 050/060, 3.0 m, 80 °C	PT 548 406 -T
High temperature measuring cable IKR 050/060, 3.0 m, 250 °C	PT 548 542 -T
Measuring cable IKR 050/060, 6.0 m, 80 °C	PT 548 407 -T
High temperature measuring cable IKR 050/060, 6.0 m, 250 °C	PT 548 543 -T
Measuring cable IKR 050/060, 10 m, 80 °C	PT 548 419 -T
High temperature measuring cable IKR 050/060, 10 m, 250 °C	PT 448 045 -T
Measuring cable IKR 050/060, 15 m, 80 °C	PT 548 483 -T
High temperature measuring cable IKR 050/060, 15 m, 250 °C	PT 548 989 -T
Measuring cable IKR 050/060, 20 m, 80 °C	PT 548 484 -T
High temperature measuring cable IKR 050/060, 20 m, 250 °C	PT 448 046 -T
Measuring cable IKR 050/060, 25 m, 80 °C	PT 548 485 -T
Measuring cable IKR 050/060, 30 m, 80 °C	PT 548 422 -T
Measuring cable IKR 050/060, 35 m, 80 °C	PT 548 486 -T
Measuring cable IKR 050/060, 40 m, 80 °C	PT 548 487 -T
Measuring cable IKR 050/060, 45 m, 80 °C	PT 548 488 -T
Measuring cable IKR 050/060, 50 m, 80 °C	PT 548 489 -T
Coax cable with SHV plugs, test voltage: 6 kV DC	

Tbl. 18: Measuring cable for IKR 050 and IKR 060

Description	Order number
Measuring cable, IKR 070, 3.0 m, 80 °C	PT 548 306 -T
Measuring cable, IKR 070, 6.0 m, 80 °C	PT 548 317 -T
Measuring cable, IKR 070, 10 m, 80 °C	PT 548 490 -T
Measuring cable, IKR 070, 15 m, 80 °C	PT 548 491 -T
Measuring cable, IKR 070, 20 m, 80 °C	PT 548 492 -T
Measuring cable, IKR 070, 30 m, 80 °C	PT 548 493 -T
Measuring cable, IKR 070, 40 m, 80 °C	PT 548 494 -T
Measuring cable, IKR 070, 45 m, 80 °C	PT 548 495 -T
Measuring cable, IKR 070, 50 m, 80 °C	BP229748-T
Triax cable with triax plugs, test voltage: 6 kV DC	

Tbl. 19: Measuring cable for IKR 070

Description	Order number
Plug, D-Sub, female, 15-pin, for IF 300 A/C, relay output	PT 441 129 -T
Plug, D-Sub, female for IF 300 A, RS-232-C	PT 441 128 -T
Relay plug complete, for IF 300 B	PT 546 999 -T
Interface cable, for IF 300 B, RS-232-C, 0.4 m	PT 548 932 -T

Tbl. 20: Plugs and interface cable

Description	Order number
Dummy plate, for interface board	PT 441 017
Dummy plate, for measurement board	PT 441 259

Tbl. 21: Dummy plates

13 Technical data and dimensions

13.1 Technical data

Parameter		Value/designation
Measuring board	PI 300 D	for Pirani gauges with wolfram filament
	PI 300 DN	for Pirani gauges with nickel filament
Number of measuring circuits		2
Measuring range (N ₂ equivalent)		1000 hPa – 8 × 10 ⁻⁴ hPa
Measuring cable length, max.		100 m
Signal output	Measurement value, analog	0 – +10 V
	Error message (error)	> 11.5 V
	Current, max.	2 mA
	Output resistance	400 Ω
Response time (10 – 90 %) with rapid pressure change	< 10 ⁻³ – 10 ³ hPa	< 50 ms
	10 ³ – < 10 ⁻³ hPa	< 600 ms
Connection, device side	TPR gauge	6-pin Amphenol C 091 B socket
	Signal output	Ø 2 mm sockets
Weight		approx. 0.14 kg

Tbl. 22: Technical data, PI 300 D / PI 300 DN

Parameter		Value/designation
Number of measuring circuits		2
Measuring range (N ₂ equivalent)		5 × 10 ⁻³ hPa – 1 × 10 ⁻⁹ hPa
Measuring cable length, max.		60 ³⁾ – 100 m
Power supply for IKR gauges	Operating voltage	3.3 kV
	Measurement current, max.	100 µA
Signal output	Measurement value, analog	0 – +10 V
	Error message (error)	> 11.5 V
	Current, max.	2 mA
	Output resistance	400 Ω
Response time (10 – 90 %) with rapid pressure change	< 10 ⁻⁹ – 10 ⁻³ hPa	< 20 ms
	10 ⁻³ – < 10 ⁻⁹ hPa	< 20 ms
Connection, device side	IKR gauge	SHV, coax, socket
	Signal output	7-pin Amphenol C 091 B socket
Weight		approx. 0.26 kg

Tbl. 23: Technical data, PE 300 DC9

3) with use of the lower measurement range limit

Parameter	Value/designation	
Number of measuring circuits	1 each of	
Measuring range (N ₂ equivalent)	Pirani	1000 hPa – 8×10^{-4} hPa
	Cold cathode	CP 300 C9 5×10^{-3} hPa – 5×10^{-9} hPa CP 300 C10 5×10^{-3} hPa – 1×10^{-10} hPa CP 300 T11/T11L 5×10^{-3} hPa – 1×10^{-11} hPa
Measuring cable length, max.	Pirani	CP 300 C9/C10/T11 100 m CP 300 T11L 500 m
	Cold cathode	CP 300 C9/C10 60 ⁴⁾ – 100 m CP 300 T11/T11L 500 m
Power supply for IKR gauge	Operating voltage	3.3 kV
	Measurement current, max.	CP 300 C9 600 μ A CP 300 C10/T11/T11L 100 μ A
Signal output	Measurement value, analog	0 – +10 V
	Error message (error)	> 11.5 V
	Current, max.	2 mA
	Output resistance	400 Ω
Response time (10 – 90 %) with rapid pressure change	Pirani	
	< 10^{-3} – 10^3 hPa	< 50 ms
	10^3 – < 10^{-3} hPa	< 600 ms
	Cold cathode	
	< 10^{-9} – 10^{-3} hPa	CP 300 C9 < 10 ms CP 300 C10/T11/T11L < 50 ms
	10^{-3} – < 10^{-9} hPa	CP 300 C9 < 10 ms CP 300 C10/T11/T11L < 50 ms

4) with use of the lower measurement range limit

Parameter		Value/designation
Connection, device side	TPR gauge	6-pin Amphenol C 091 B socket
	IKR gauge	CP 300 C9/C10 SHV, coax, socket CP 300 T11/T11L triax, socket
	Signal output	Ø 2 mm sockets
Weight		CP 300 C9 approx. 0.21 kg CP 300 C10 approx. 0.23 kg CP 300 T11/T11L approx. 0.25 kg

Tbl. 24: Technical data, CP 300 C9/C10/T11/T11L

Parameter		Value/designation
Relay	Quantity, number	5
	Contacts	1 x switching contact, potential-free, max. 50 V AC against other contacts and against ground
AC characteristics	Switching voltage, max.	50 V AC
	Switching current, max.	1.5 A
	Switching output, max.	75 VA
DC characteristics	Switching current, max.	Switching voltages > 50 V DC are not permitted for safety reasons. 0.6 A with 50 V DC 0.8 A with 40 V DC 1.5 A with 30 V DC
	Switching output, max.	-
Connection, device side		D-Sub plug, 15-pin, pins
Electrical resistance with plug		125 mΩ
Interface	Type	RS-232-C, asynchronous
	Baud rates	300, 1200, 2400, 4800, 9600
	Data format	ASCII, 1 start bit, 8 data bits, 1 stop bit, no parity bit
	Connection, device side	D-Sub plug, 9-pin, pins
	Cable length, max.	30 m
Weight		approx. 0.14 kg

Tbl. 25: Technical data IF 300A

Parameter		Value/designation
Relay	Quantity, number	5
	Contacts	1 x switching contact, potential-free, max. 250 V AC against other contacts and against ground
AC characteristics	Switching voltage, max.	250 V AC
	Switching current, max.	4 A
	Switching output, max.	1000 VA

Parameter		Value/designation
DC characteristics	Switching current, max.	0.25 A with 200 V DC 0.3 A with 140 V DC 0.4 A with 100 V DC 0.5 A with 60 V DC 0.6 A with 50 V DC 0.8 A with 40 V DC 4.0 A with 30 V DC
	Switching output, max.	120 W
Connection, device side		GdsA-H, DIN 41612, 15-pin, pins
Electrical resistance with plug		70 mΩ
Interface	Type	RS-232-C, asynchronous
	Baud rates	300, 1200, 2400, 4800, 9600
	Data format	ASCII, 1 start bit, 8 data bits, 1 stop bit, no parity bit
	Connection, device side	0.4 m cable with D-Sub plug 25-pin, pins
	Cable length, max.	30 m
Weight		approx. 0.15 kg

Tbl. 26: Technical data IF 300B

Parameter		Value/designation
Relay	Quantity, number	5
	Contacts	1 x switching contact, potential-free, max. 50 V AC against other contacts and against ground
AC characteristics	Switching voltage, max.	50 V AC
	Switching current, max.	1.5 A
	Switching output, max.	75 VA
DC characteristics	Switching current, max.	Switching voltages > 50 V DC are not permitted for safety reasons. 0.6 A with 50 V DC 0.8 A with 40 V DC 1.5 A with 30 V DC
	Switching output, max.	-
Connection, device side		D-Sub plug, 15-pin, pins
Electrical resistance with plug		125 mΩ
Interface	Type	RS-422, asynchronous
	Baud rates	300, 1200, 2400, 4800, 9600
	Data format	ASCII, 1 start bit, 8 data bits, 1 stop bit, no parity bit
	Connection, device side	D-Sub plug 9-pin, sockets
	Cable length, max.	1200 m
Weight		approx. 0.14 kg

Tbl. 27: Technical data, IF 300 C

Parameter		Value/designation
Relay	Quantity, number	5
	Contacts	1 x switching contact, potential-free, max. 50 V AC against other contacts and against ground
AC characteristics	Switching voltage, max.	50 V AC
	Switching current, max.	1.5 A
	Switching output, max.	75 VA

Parameter		Value/designation
DC characteristics	Switching current, max.	Switching voltages > 50 V DC are not permitted for safety reasons. 0.6 A with 50 V DC 0.8 A with 40 V DC 1.5 A with 30 V DC
	Switching output, max.	-
Connection, device side		D-Sub plug, 15-pin, pins
Electrical resistance with plug		125 mΩ
Interface	Type	Profibus DP
	Baud rates	≤ 12 Mbaud
	Data format	(see communication instructions)
	Connection, device side	D-Sub plug 9-pin, sockets
	Cable length, max.	(see communication instructions)
Weight		approx. 0.16 kg

Tbl. 28: Technical data, IF 300 P

Parameter		Value/designation
Interface	Type	Profinet
	Baud rate	100 Mbit/s
	Connection, device side	2× RJ-45, 8-pin
Weight		approx. 0.16 kg

Tbl. 29: Technical data, IF 500 PN

13.2 Dimensions

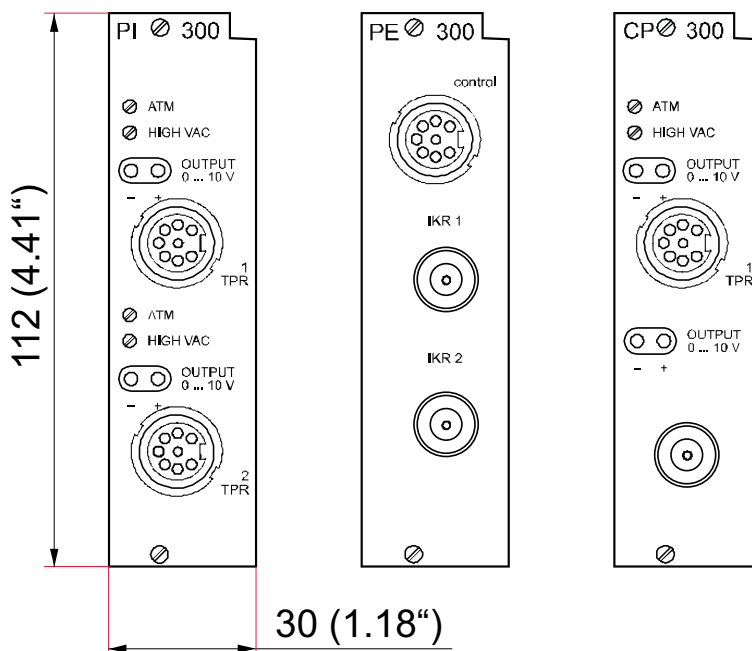

Fig. 19: Dimensions of measurement boards
Dimensions in mm

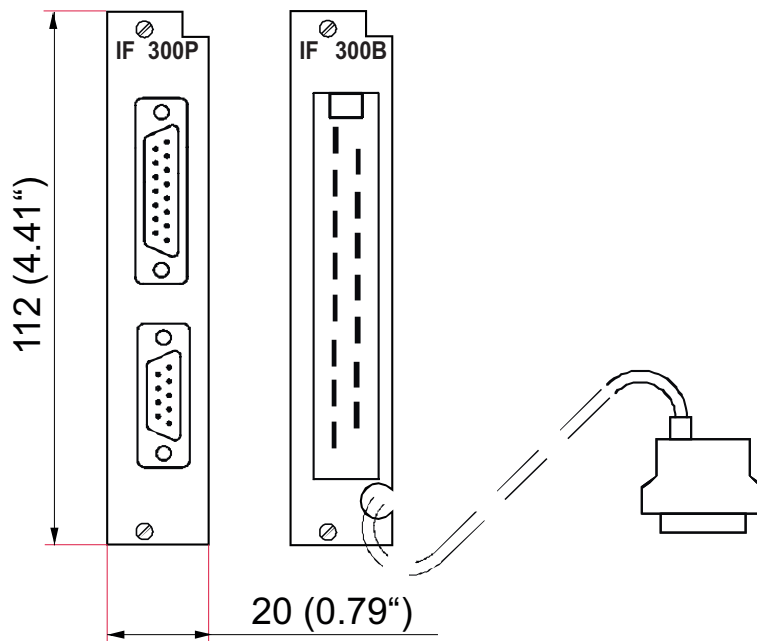

Fig. 20: Dimensions of interface and relay boards
Dimensions in mm

14 Appendix

14.1 Units of pressure

Unit	mbar	bar	Pa	hPa	kPa	Torr / mm Hg
mbar	1	$1 \cdot 10^{-3}$	100	1	0.1	0.75
bar	1000	1	$1 \cdot 10^5$	1000	100	750
Pa	0.01	$1 \cdot 10^{-5}$	1	0.01	$1 \cdot 10^{-3}$	$7.5 \cdot 10^{-3}$
hPa	1	$1 \cdot 10^{-3}$	100	1	0.1	0.75
kPa	10	0.01	1000	10	1	7.5
Torr / mm Hg	1.33	$1.33 \cdot 10^{-3}$	133.32	1.33	0.133	1

1 Pa = 1 N/m²

Tbl. 30: Units of pressure and their conversion

14.2 Gas throughputs

Unit	mbar l/s	Pa m ³ /s	sccm	Torr l/s	atm cm ³ /s
mbar l/s	1	0.1	59.2	0.75	0.987
Pa m ³ /s	10	1	592	7.5	9.87
sccm	$1.69 \cdot 10^{-2}$	$1.69 \cdot 10^{-3}$	1	$1.27 \cdot 10^{-2}$	$1.67 \cdot 10^{-2}$
Torr l/s	1.33	0.133	78.9	1	1.32
atm cm ³ /s	1.01	0.101	59.8	0.76	1

Tbl. 31: Gas throughputs and their conversion

14.3 Converting measuring signal and pressure

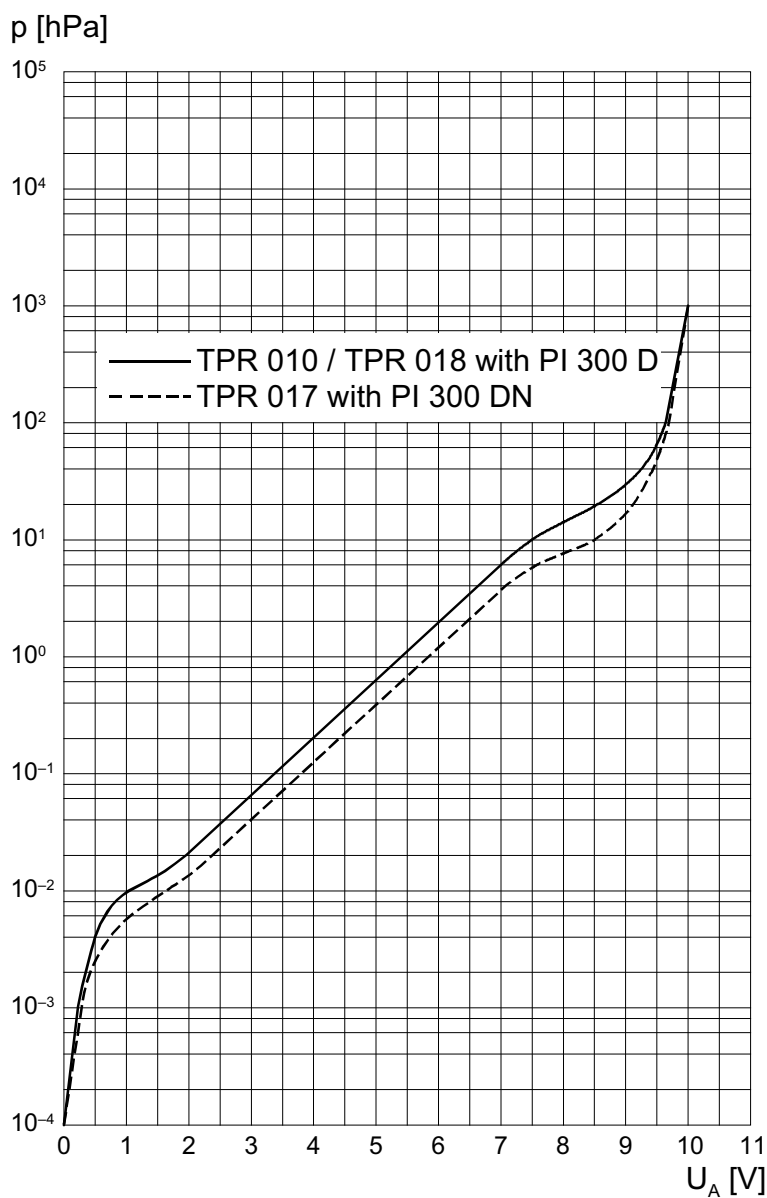

Fig. 21: Relationship between measuring signal and pressure for TPR gauges

p Pressure U_A Measuring signal [V] (output voltage)

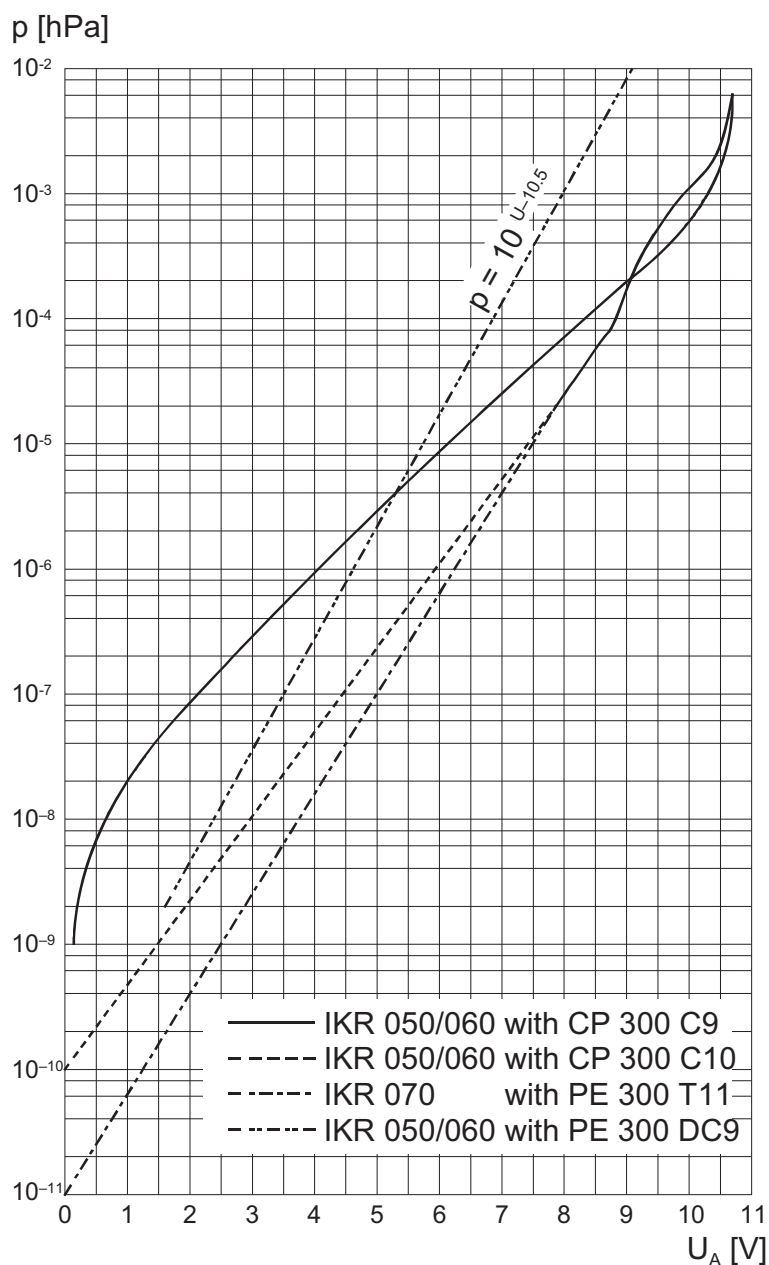

Fig. 22: Relationship between measuring signal and pressure for IKR gauges

p Pressure

U_A Measuring signal [V] (output voltage)

14.4 Gas type dependence

The measuring signal is gas type-dependent. The characteristics apply for nitrogen (N_2), oxygen (O_2), dry air and carbon monoxide (CO).

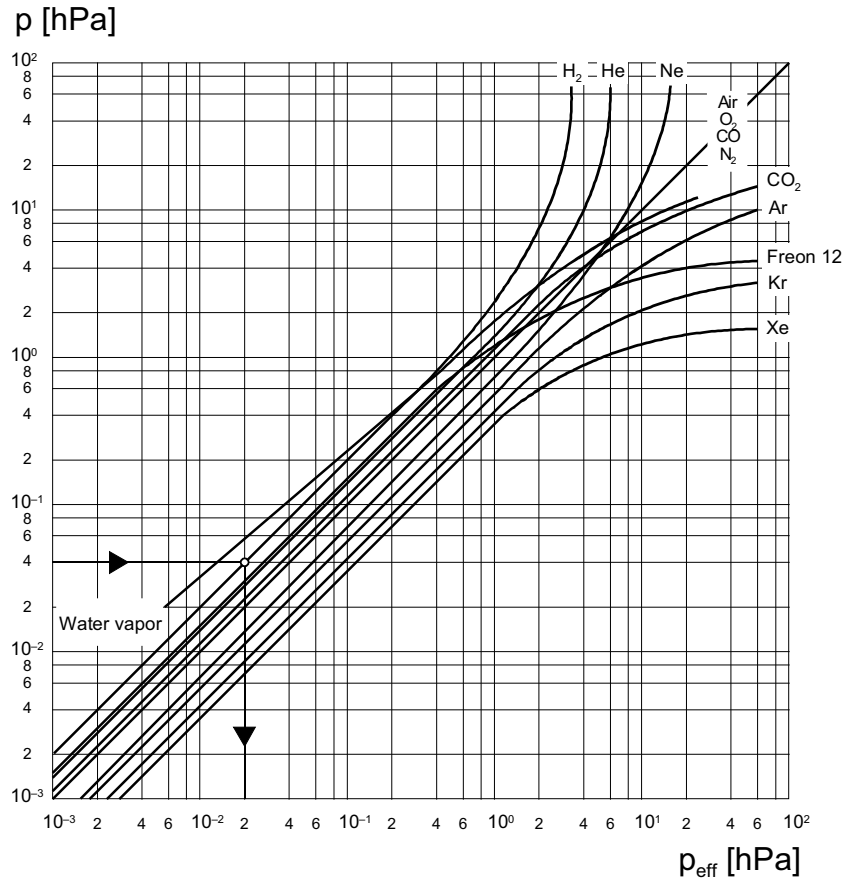

Fig. 23: Displayed pressure for TPR gauges

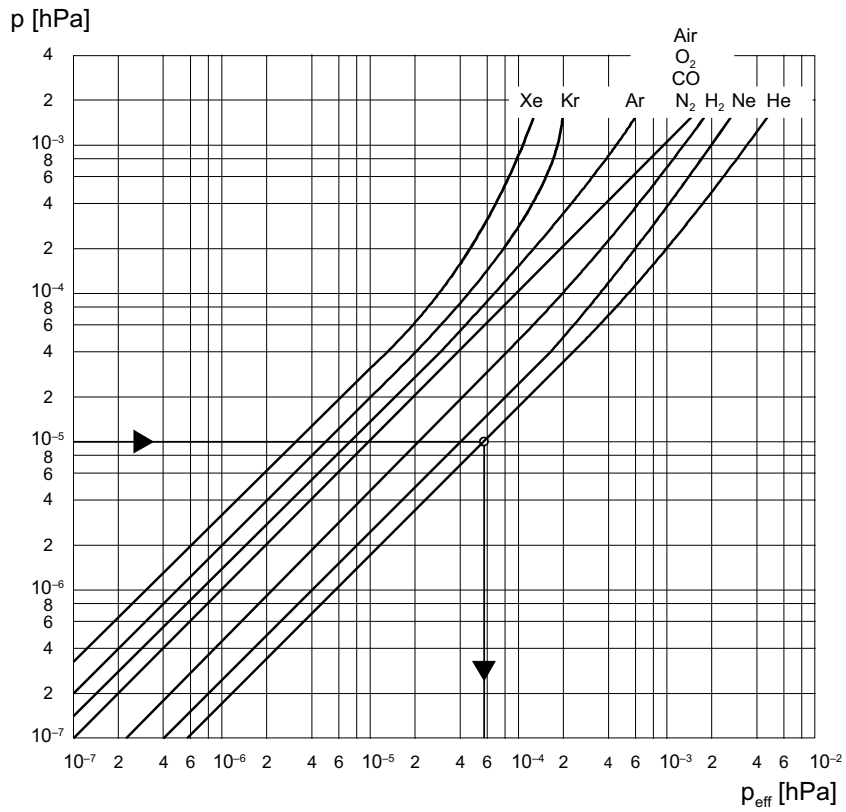

Fig. 24: Displayed pressure for IKR gauges

VACUUM SOLUTIONS FROM A SINGLE SOURCE

Pfeiffer Vacuum stands for innovative and custom vacuum solutions worldwide, technological perfection, competent advice and reliable service.

COMPLETE RANGE OF PRODUCTS

From a single component to complex systems:

We are the only supplier of vacuum technology that provides a complete product portfolio.

COMPETENCE IN THEORY AND PRACTICE

Benefit from our know-how and our portfolio of training opportunities!

We support you with your plant layout and provide first-class on-site service worldwide.

ed. D - Date 2303 - P/N:BG5972BEN



Are you looking for a
perfect vacuum solution?
Please contact us

Pfeiffer Vacuum GmbH
Headquarters • Germany
T +49 6441 802-0
info@pfeiffer-vacuum.de

www.pfeiffer-vacuum.com

PFEIFFER  **VACUUM**